



B4WBCLASSIC— WINGLINESM

4. CLASSIC WINGLINE STYLE BENCH WITH BACK SURFACE MOUNT DESIGN

WEBCOAT PRODUCTS
P.O. BOX 3160
McALESTER, OKLAHOMA 74501
1-800-505-5101
FAX: (918)426-5924
E-MAIL: WEBCOAT@WEBCOAT.COM

Please take the time to locate and identify each part. Assemble the units on a smooth flat surface. It is also helpful to lay the tops and seats on cardboard or a drop cloth to prevent scratching of the surface during assembly. All parts have been pre-cut and pre-drilled for ease of assembly. All holes are slotted to allow for easy assembly and for final levelling of tops and seats to frames. Fully assemble all parts without totally tightening nuts and bolts. After all assembled go back and retighten nuts to bolts. DO NOT OVER TIGHTEN NUTS TO BOLTS. Over tightened nuts can crack the plastisol coating. All the necessary quantities of parts required are listed in this assembly instructions.

DO NOT BEGIN ASSEMBLY UNTIL YOU HAVE READ THESE INSTRUCTIONS AND ARE FAMILIAR WITH THE PARTS.



PARTS IDENTIFICATION

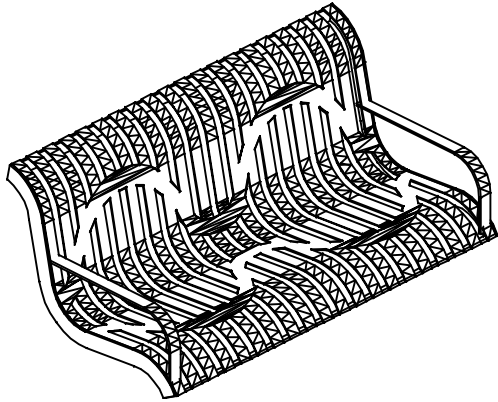

(A) 4' CLASSICWINGLINE BENCH

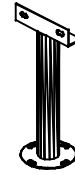

(B) BENCH FRAME

PARTS LIST

ITEM	PART#	DESCRIPTION	QTY.
A	S4CLASWING	4' CLASS WING SEAT	1
B	FSM	FRAME	2

ITEM	HARDWARE DESCRIPTION	QTY.
HW1	5/28" NYLON NYL LOCKNUTS	8
HW2	5/28" WASHERS CAP BOLTS	8
HW3	5/16" FLAT WASHERS	16
HW4	BOLT GUARDS	8

ASSEMBLY TOOLS REQUIRED

HARDWARE IDENTIFICATION



(HW1) 5/16" X 18
NYL LOCKNUTS

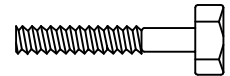

(HW2) 5/16" X 18
GAUGE CAP BOLTS



(HW3) 5/16"
FLAT WASHERS



(HW4) BOLT
GUARDS

ASSEMBLY PROCEDURES

STEP 1

MOUNT SEAT TO FRAMES AS SHOWN BELOW BY MEANS OF EIGHT 5/16" BOLTS, SIXTEEN FLAT WASHERS AND EIGHT NUTS, THROUGH THE SLOTTED HOLES IN THE SEAT END PLATES AND THE SLOTTED HOLES ON BOTH ENDS OF THE FRAME.

STEP 2

TIGHTEN ALL NUTS ON ALL BOLTS AND PLACE THE BOLT GUARDS ON ALL NUTS. **DO NOT OVER TIGHTEN THE NUTS AS THIS COULD CAUSE THE PLASTISOL COATING TO CRACK.**

STEP 3

CAREFULLY SET BENCH UPRIGHT AND MOUNT THE SURFACE MOUNT FRAMES TO THE SELECTED SURFACE. **SURFACE MOUNTING HARDWARE NOT INCLUDED.**



1	CAP. BOLT & WASHER
2	WASHER & LOCK NUT

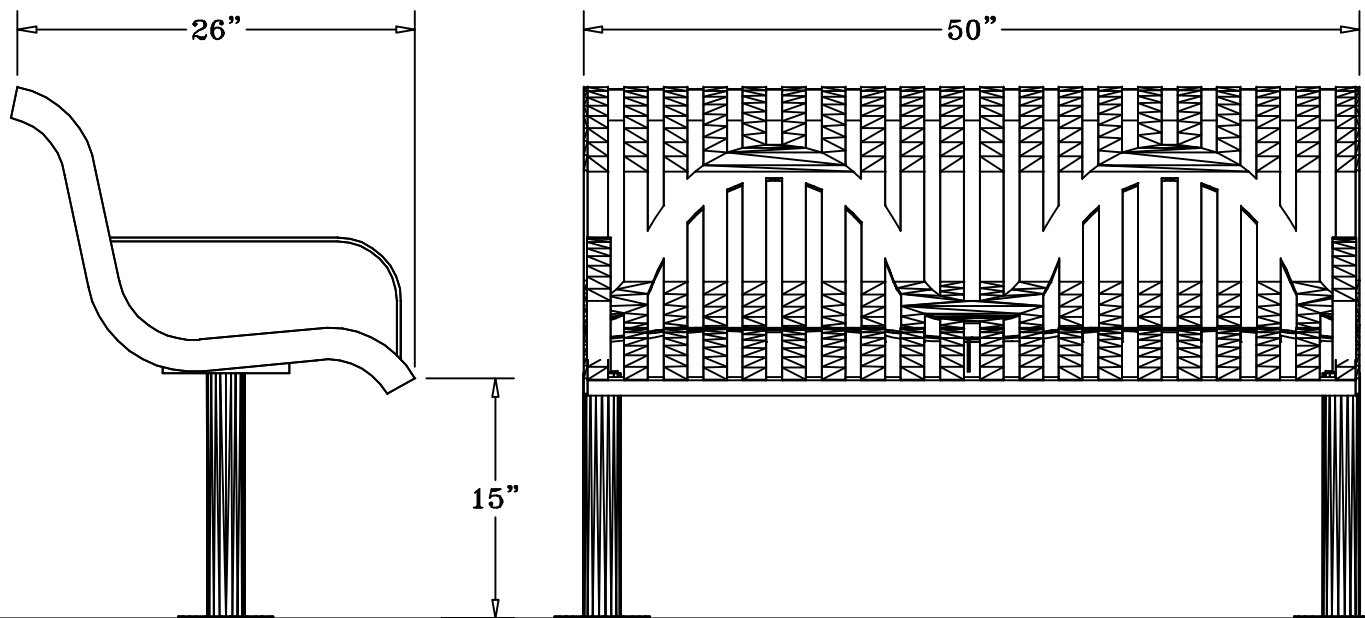

SPECIFICATIONS

4' POLY VINYL COATED CLASSIC WINGLINE STYLE BENCH WITH BACK.
FRAME IS SURFCE MOUNT DESIGN.

COATED WITH A 1/8" TO 1/4" THICK PLASTISOL ULTRAVIOLET STABILIZED VINYL COATING
FUSED AND BAKED TO A 90% GLOSS.

SEAT HEIGHT IS 15" APPROXIMATELY.

TOTAL OVERALL DIMENSIONS ARE 48" X 26" APPROXIMATELY.

SEAT IS MADE FROM 11 GA. STEEL.

FRAMES ARE MADE OF 2 3/8" HEAVY GALVANIZED STEEL TUBING THAT IS GALVANIZED INSIDE
AND OUT AND MEETS OR EXCEEDS THE YIELD AND TENSILE OF SCH 40 PIPE. CONSTRUCTED
SO AS TO PROHIBIT RAIN WATER FROM COLLECTING AT GROUND LEVEL. COATED WITH A BAKED
ON POLYESTER POWDER COAT FINISH.

SURFACE MOUNT PLATE IS MADE OF 1/4 FLAT STEEL.

ALL HARDWARE IS NON-CORROSIVE.

WEIGHT FOR THE B4WBCLASSICWINGLINESM IS 99 LBS.

MAINTENANCE

To maintain luster it is recommended to wash, rinse, and dry the units after prolonged use.
Check for loose bolts and nuts and tighten as needed. Contact the factory for genuine
Webcoat part replacements if needed.